

Automatic filter AF 112 G

Cast design with internal pressure cleaning and integrated cyclone effect
Connection size: flange DN 40 or G1 1/2

1. Short description

Filtration Group automatic backflush filters are suitable for all applications where low-viscosity liquids have to be filtered.

These compact, inline filter systems are designed for automatic cleaning. The system is cleaned by rotating the filter element and backflushing with internal pressure media.

Advantages:

- Extended filter service life due to the use of a cleanable element
- Cleaning is possible without interrupting filtration
- Precise separation quality in accordance with the surface filtering principle
- Top-quality, asymmetric filter medium made of multiple-sintered stainless steel fleece on a rugged core element
- Efficient filter cleaning assures maximum process stability
- Solid construction and high-quality materials for a long service life
- Minimal liquid loss during cleaning
- Continuous cleaning without valves
- Filter cleaned one segment at a time with a high backflush pulse
- Actual filter rating and nominal separation are indicated
- Integrated preseparation thanks to tangential inflow and preseparator tube
- Material variants open up a wide range of applications
- Filtration Group modular Vario system for optimum filter selection
- Application in Ex zone 1 and 2 optional
- Easy maintenance
- Worldwide sales



2. Operating principle

The Filtration Group AF 112 G backflush filter belongs to the small Vario series. The compact Filtration Group automatic filter system is used for fine and micro-filtration of a variety of low-viscosity liquids.

This inline pressure filter consumes no filter material, which means there is also no need for subsequent disposal. The filter is cleaned without interrupting operation. The concentrated solids are drained off simply by opening the system for a short time. Optional a pneumatical rotary drive is also available. Its advance is given by use with the differential pressure measure and display unit with integrated control function PiC 3170 MFC. Autarcic automatic filters can be combined without need of a power station for a 3-phase motor. 24 V DC field voltage and compressed air as auxilliary energy are sufficient. The concentrated solids are drained off simply by opening the system for a short time.

The medium to be cleaned is guided into the filter housing under pressure and flows inward through the Filtration Group segmented element. Particles settle on the surface of the filter medium. The filtered fluid exits the filter housing at the top opposite the inlet connection.

The integrated preseparator relieves the load on the segmented element, particularly from coarse and heavy particles. This is achieved by a tangential flow around the preseparator tube and the deflection edges.

The filter is cleaned when a preset differential pressure limit, a set interval or a defined filtered fluid quantity is reached. The segmented element is turned as the cleaning pressure valve is opened. The segments are then guided one at a time past the flushing channel on the outer circumference, causing them to open and close alternately. The internal pressure is built up at a throttling point downstream of the filter, so that when one segment opens, an outward surge cleans the separated particles from the filter material. As a result of this pulse cleaning principle, the particles are catapulted out, collected in the flushing channel and discharged with a small amount of internal medium. One turn is sufficient to clean all segments. The residue that has settled in the collection cone can be emptied via the drain valve either when the machine is at a standstill or during filtration. All filters of the Filtration Group Vario series are protected by various patents.

Used Filtration Group filter elements in the AF 112 G backflush filter:

Filtration Group Topmesh:

- Good cleanability due to asymmetric design
- High free surface portion
- Defined particle retention
- Several material combinations possible

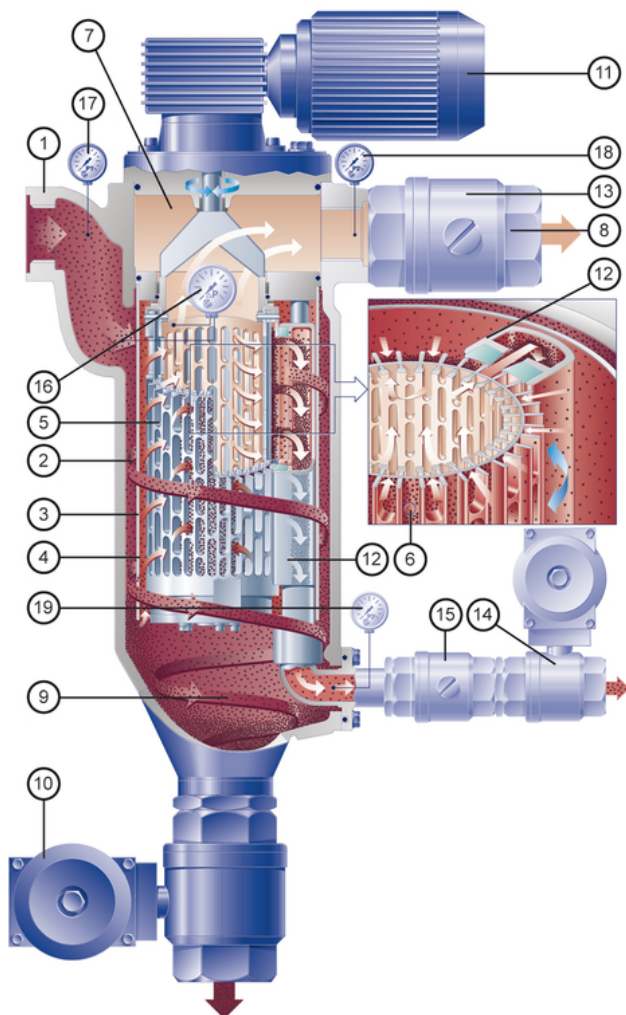
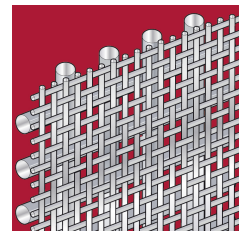

- 1 Inlet connection
- 2 Outer inlet plenum
- 3 Preseparator tube
- 4 Inner inlet plenum
- 5 Filtration Group segment element
- 6 Filtration Group filter materials
- 7 Plenum for filtered fluid
- 8 Drain connection for filtered fluid
- 9 Residue collection cone
- 10 Drain valve
- 11 Drive motor
- 12 Flushing channel
- 13 P2-control throttle
- 14 Cleaning valve
- 15 P3-control throttle (not always required)
- 16 Differential pressure contact gauge
- 17 P1-gauge
- 18 P2-gauge
- 19 P3-gauge (not always required)

3. Technical data

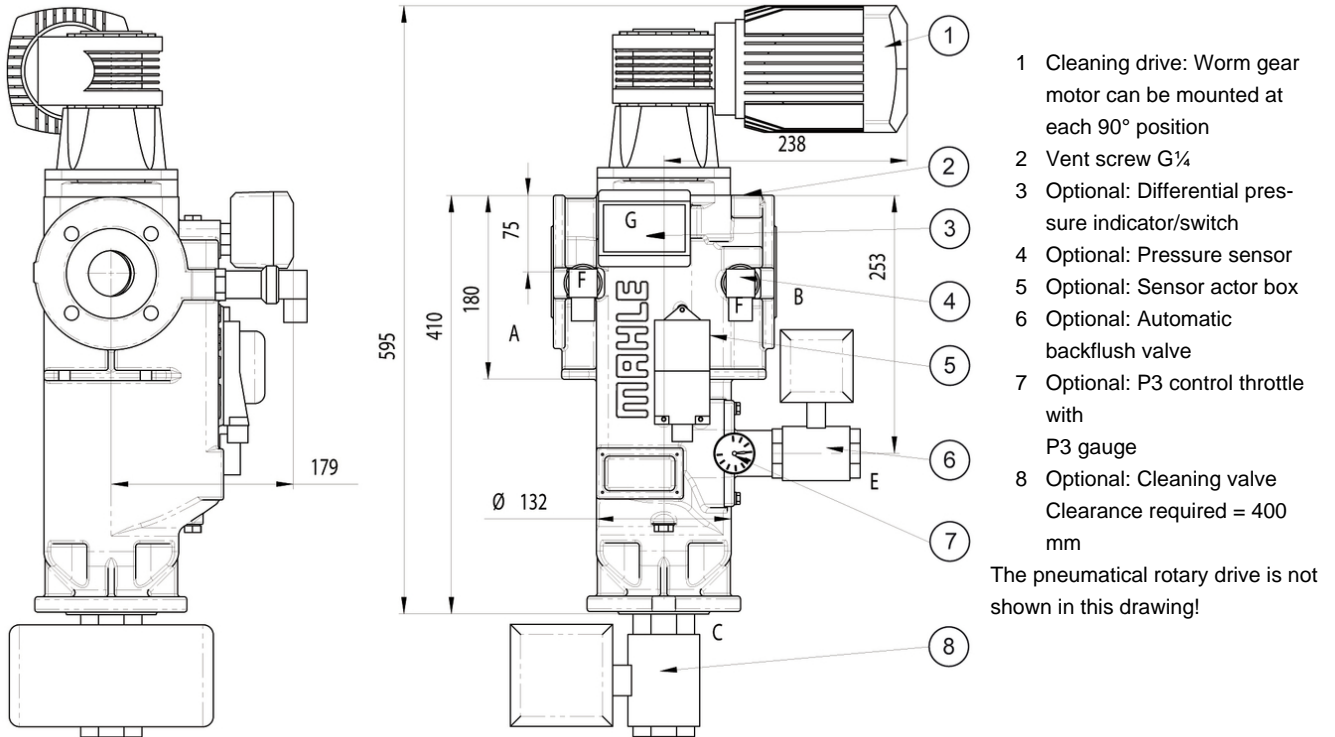

Filter data

Max. operating pressure: 16 bar
 Max. operating temperature: 100 °C

Materials:

- Housing and cover: cast steel
- Internals: C-steel, PPS GF40, Al
- Bearing bushes: PTFE based
- Seals: FPM (Viton)
- Segmented element: 1.4571/Al or 1.4571/Alhc (Δp max. 10 bar)

Cover lock: 4x M16 hexagon screws

Connections and nominal diameters:

- A-inlet, B-outlet, C-drain: G1½ threaded holes DIN 3852 form Z in flange DN 40
- E-backflush: G1 DIN 3852 form Z
- F-gauge: G½ DIN 3852 form Z
- G-indicator: G1/8 DIN 3852 form X

Drive shaft seal: Lip seal with O-ring

External finish: Synthetic resin primer, blue acc. to RAL 5007

Motor data

Worm gear motor
 Multi-range winding

V	Hz	kW	U/min	A
Δ 230 ± 10%	50	0.18	17	1.2
λ 400 ± 10%	50	0.18	17	0.7
Δ 266 ± 10%	60	0.22	17	1.1
λ 460 ± 10%	60	0.22	17	0.7

Protection class: IP55; insulation class F; output torque: 97 Nm

Optional:

- Ex protection acc. to ATEX 2014/34/EU
- Electrical design in Ex II 2G T3
- Mechanical design in Ex II 2G c T3
- Pneumatical rotary drive

Weight: 36 kg (with motor) or 32 kg (with pneumatical rotary drive)

Volume: 8 l

Other versions available on request!

Technical data is subject to change without notice.

4. Design and application

Element type (see section 6)	Total surface in cm ²	Filter rating in μm/ effective filter surface in cm ²							
		10	20	30	40	60	80	100	
AF 100XX4	437	310	310	310	310	310	310	310	310

Recommended design

Cleaning and discharge modes

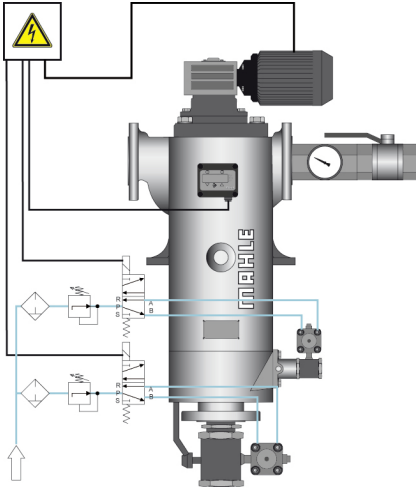

Fully automatic operation:

Filtration usually takes place under pressure. The filter is cleaned after a programmed time or a preset number of cycles or according to the differential pressure. We recommend cleaning the system at a differential pressure of approximately 0.5 - 0.7 bar. The cleaning motor is operated for around 3 seconds (about one turn of the element). The cleaning valve remains open for this period. An internal pressure of 2 - 3 bar is adequate to clean the filter efficiently.

The drain valve is opened in order to discharge the filter. Depending on the residue concentration, this can either take place directly after cleaning or be time or cycle controlled. The opening time of the drain valve is 2 - 3 seconds.

Refer to the Instruction Manual for further information.

Filtration Group's team of specialists will be pleased to assist in any way. Tests can be carried out in the absence of reliable evaluation criteria.

5. Performance curves

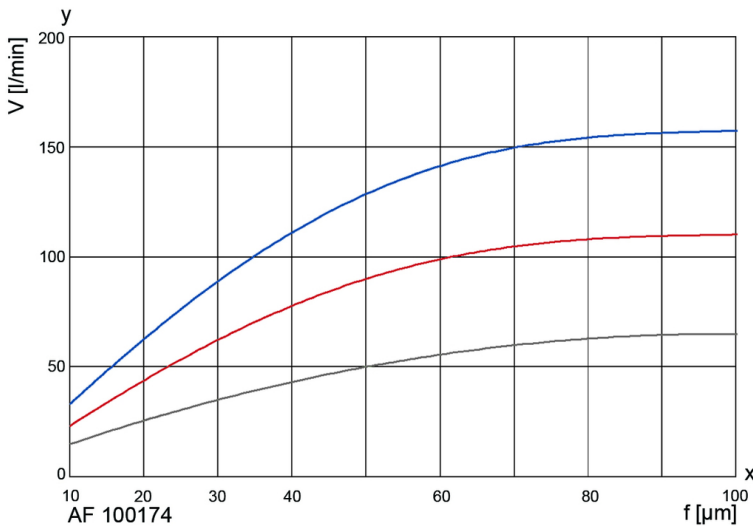

The curves indicate the volume flow through the complete filter system (filter housing including element) and are referred to a differential pressure of 0.3 bar. Specific process information is essential to guarantee reliable operation of an automatic filter.

Viscosity in mm²/s

- 1 mm²/s
- 33 mm²/s
- 100 mm²/s

y = Volume flow V [l/min]

x = Filter rating f [μm]

6. Type number key

Type number key with selection example for AF 11243-221-41220/G2

Size

AF 1124 1 x 65x230 No. of steps x diameter x length [mm]

Cleaning drive

- 3 Gear motor 230/400 V, 50 Hz or 266/460 V, 60 Hz
- 4 Gear motor 230/400 V, 50 Hz Ex II 2G T3
- 7 Pneumatically rotary drive

Inlet and outlet connections

- 2 G1½ in flange DN 40 PN 16

Permissible operating pressure in bar (housing/cover)

- 2 PN 16

Material Seal FPM, PU, bearing PTFE

- 1 Cover and housing nodular cast iron, internals steel, aluminium
- 3 Cover and housing nodular cast iron, internals stainless steel 1.4301/1.4571

Differential pressure indicator and gauge

- 1 PiS 3076, switching level at 1.2 bar, static 63 bar, aluminium/FPM
- 2 PiS 3076, switching level at 0.7 bar, static 63 bar, aluminium/FPM
- 3 PiS 3170 MFC, digital #p gauge with control function in combination with pneumatically rotary drive
- 4 PiS 3170, digital Δp gauge, 2 switching levels settable from 0 to 16 bar

Valves and control throttles

- 1 P2 control throttle with P2 gauge
- 6 Like 1 but with P3 control throttle and P3 gauge

Drain valve

- 2 Ball valve, electropneumatic 24 V DC
- 3 Ball valve, electropneumatic 230 V AC
- 4 Ball valve, electric 24 V DC
- 5 Ball valve, electric 230 V AC

Abreinigungsventil

- 2 Ball valve, electropneumatic 24 V DC
- 3 Ball valve, electropneumatic 230 V AC
- 4 Ball valve, electric 24 V DC
- 5 Ball valve, electric 230 V AC

Optional features

- 0 Without/special version

AF 1124 3 - 2 2 1 -4 1 2 2 0 -XXXX (end number for special version)/G2*

*end number completion:

G2 cast iron, Version 2

End number	Special version
3001	Standard filter insert (complete), without housing or drive
3002	Standard filter insert (complete), without housing, with drive
3700	PTFE seals
Other numbers	On request

Type number key with selection example for element for AF 100

Series

AF 100 Segmented cartridge with topmesh (10 µm to 100 µm)

Material	Core element	Filter medium	Clamp rings	Wire width in mm
Segmented element				
17	Al	1.4571	St	-
20	Al/hc	1.4571	1.4571	-

Overall length Diameter x length in mm

4 65x230

Gap width/rating in µm (see 4. Design and application)

001	10 µm	004	40 µm	010	100 µm
002	20 µm	006	60 µm		
003	30 µm	008	80 µm		

Other filter ratings on request

AF 100 17 4 - 006

For the correct choice of the filter fineness please consult the table on page 4.

7. Spare parts

No.	Designation	Material no.	
		FPM/C steel	PTFE/VA
1	Bush kit		70308169
2	Set of seals (complete)	70368610	70316071
3	Backflush channel moulding	79744004	70312375
4	Backflush channel		70345207
5	Cartridge		see name-plate

Please contact us for detailed technical information, any open questions about options, accessories and for general expert advice. Completion of the relevant questionnaire would facilitate in the coordination of all important parameters. Comprehensive documentation on our filter range, filter elements and accessories can be provided. About installation and operation, please refer to the Instruction Manual.

Filtration Group GmbH
 Schleifbachweg 45
 D-74613 Öhringen
 Phone +49 7941 6466-0
 Fax +49 7941 6466-429
 sales@filtrationgroup.com
 www.filtrationgroup.com
 70365279.01/2017